

RELEASE

DATE:

COMPANY:

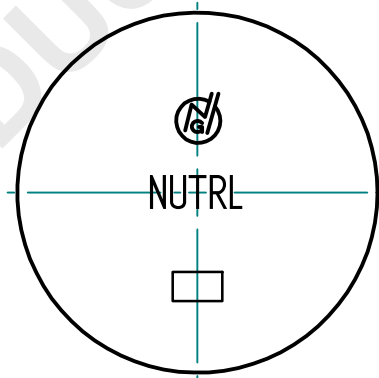
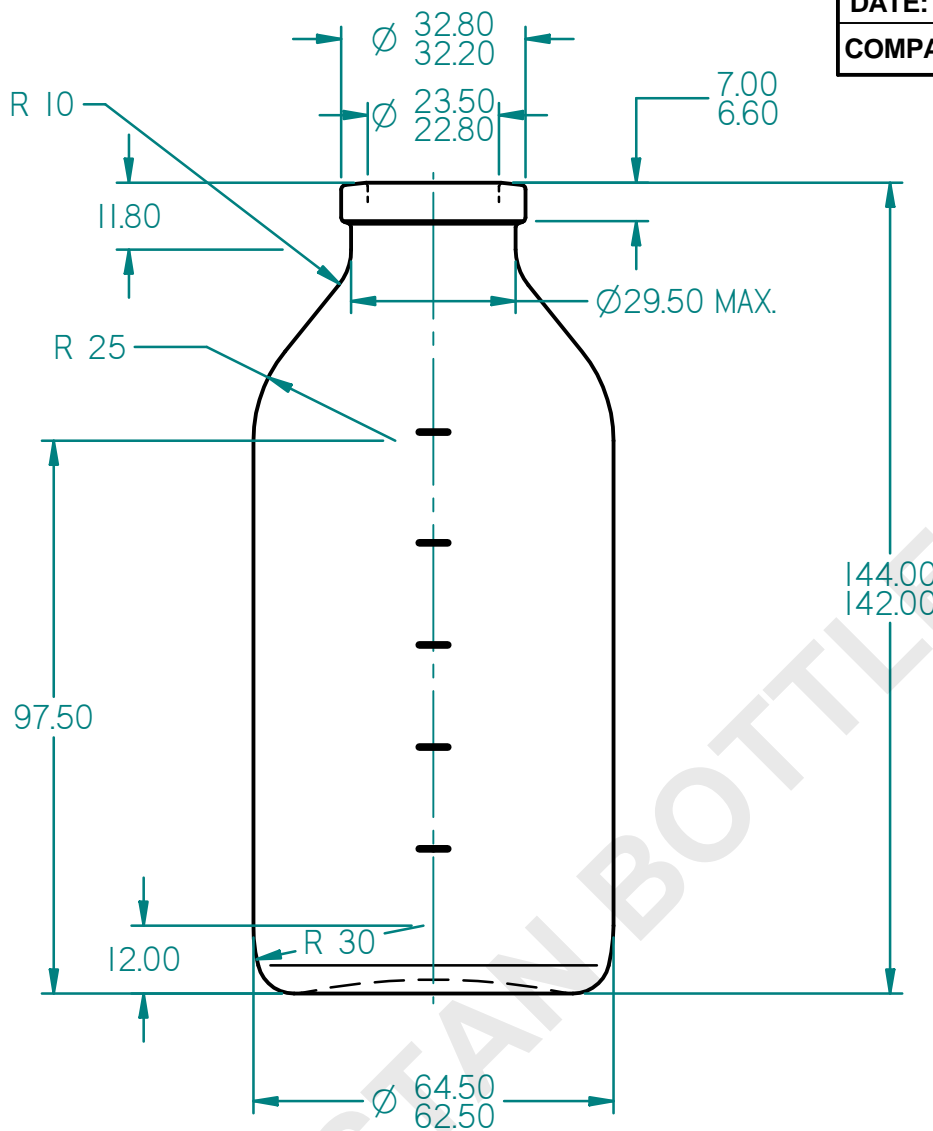

Protective note ISO 16016 observed

GENERAL TOLERANCES DIN 6129-1 (DIMENSIONS WITHOUT TOLERANCES ARE FOR REFERENCE ONLY)				FINISH: 32 mm P.N.		O'FLOW CAPACITY: 289.0 - 305.0 ml		ARTICLE NO.: 5156210100			
				FINISH DWG: NA		WEIGHT: 200 g Approx					
				FINISH MOLD NO: 142		TYPE OF GLASS: I COLOUR: FLINT					
				DATE	NAME	TITLE: 250 ml P / N					
				DRAWN	22/11/2013					Paresh	
				CHECKED	22/11/2013					H.B.P.	
				SCALE	1 : 1.33						
				 NEUTRAL GLASS & ALLIED INDS. PVT. LTD. MUMBAI / KOSAMBA			MOLD NO.:	DRAWING NO.:	REVISION	SHEET	FORMAT
							156	B 6210	0	1 OF 1	A4
REV.	CHANGE	DATE	NAME				FILE: 250 ml PN.dft				